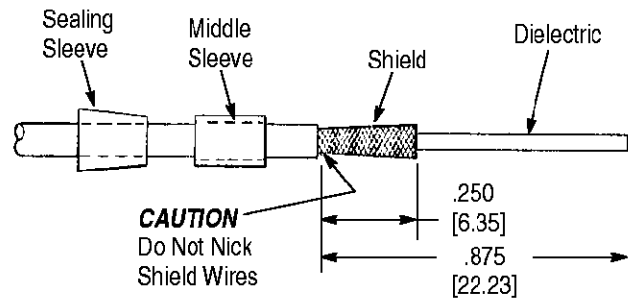

Figure 1

INTRODUCTION

This instruction sheet covers the assembly procedures for Golden Crimp and Crimp Silver Right-Angle Connectors. See Figure 1.

NOTE Dimensions on this sheet are in inches [with millimeters in brackets]. Figures and illustrations are for identification only and are not drawn to scale.



NOTE: Not to Scale

Figure 2

Step 1

Slip sealing sleeve and middle sleeve on cable and strip to dimensions shown in Figure 2.

Fan shield slightly, but do not unbraid.

CAUTION

Extreme care must be taken to avoid nicking or cutting shield wires when trimming jacket.

Note: For assembly to cable with "Mini-Noise" coating, Mini-Noise coating must be removed from surface of cable dielectric as follows:

1. Painted Coatings: Wipe off dielectric surface with a dry cloth. Wipe again using paint thinner or trichloroethane. Do not immerse cable in solvent.
2. Tape or Fused Coatings: Remove with sandpaper, file, or scraping action of razor blade. Do not damage dielectric.

DANGER

To prevent personal injury, use caution when handling file or razor blade.

Step 2

Slide inner sleeve, small end first, over dielectric and under the shield until shield wires are flush with shoulder.

Trim excess shield if necessary.

Slide middle sleeve flush with shoulder of inner sleeve. Slide sealing sleeve until it butts against the middle sleeve as shown in Figure 3.

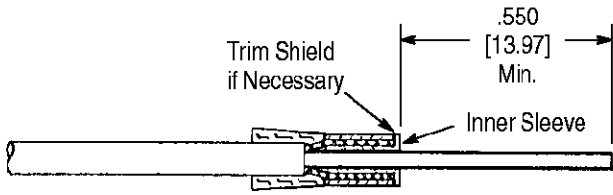

Figure 3

Step 3

Insert assembled components into rear of housing subassembly. Make sure it is properly fitted and in as far as possible. Rotate while pushing to secure a tight fit. See Figure 4.

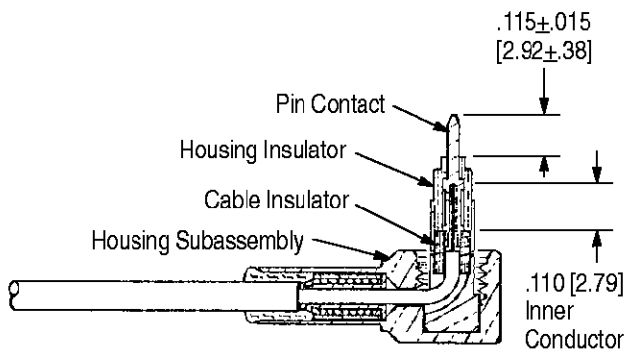

Figure 4

Crimp rear of housing with proper housing crimp tool listed in Figure 5.

TYCO ELECTRONICS PART NO.	MICRODOT PART NO.	THOMAS & BETTS™ PART NO.	MAX. CABLE DIA.
4-1532129-4	010-0081-0000	WT-400	.088 [2.24]
4-1532129-5	010-0082-0000	WT-402	.110 [2.79]
3-1532136-7	010-0083-0000	WT-406	.155 [3.94]

Figure 5

Step 4

Trim dielectric flush with face of housing subassembly as shown in Figure 4.

CAUTION Do not nick inner conductor wires.

Step 5

Locate cable insulator over dielectric and press into counterbore of housing subassembly.

Trim inner conductor to length shown in Figure 4.

Step 6

Locate the pin contact over the inner conductor and press into the cable insulator until the shoulder on the

- Product of Astro Tool Corp.
- Consult manufacturer's literature for current information.

contact is firmly against the cable insulator. See Figure 4.

Inner conductor must be visible through the inspection hole.

Crimp the contact in place with any one of the contact crimp tools listed in Figure 6.

TYCO ELECTRONICS PART NUMBER	MICRODOT PART NUMBER	MFG'S PART NUMBER
4-1532129-3	010-0065-0000	Astro Tool Number 810D1●●
3-1532136-9	010-0134-0000 (Setting #1) 001-0104-0000 (Locator)	DANIELS™ #MH750● (Setting #1) #P79 (Locator)

Figure 6

Step 7

Press the housing insulator over the pin contact until seated in place. See Figure 4.

NOTE This applies only for connectors with housing insulator packed loose.

Step 8

The final step is to thread and securely tighten the ferrule or ferrule subassembly in place.

The recommended torque value is 90-100 inch-ounces.

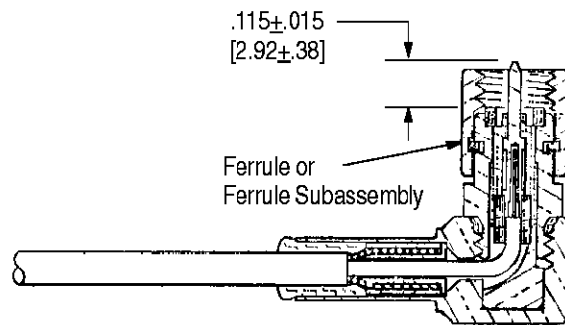

Figure 7

Notes: (Unless otherwise specified)

Test Voltage – 1000 V.R.M.S.

Insulation Resistance – 5.0 x 10⁹ Ohms Min.

REVISION SUMMARY

Per EC 0990-0804-01

- Initial release of instruction sheet